

PAN WASHER HEAD TIMBER SCREWS WITH CUTTING POINT

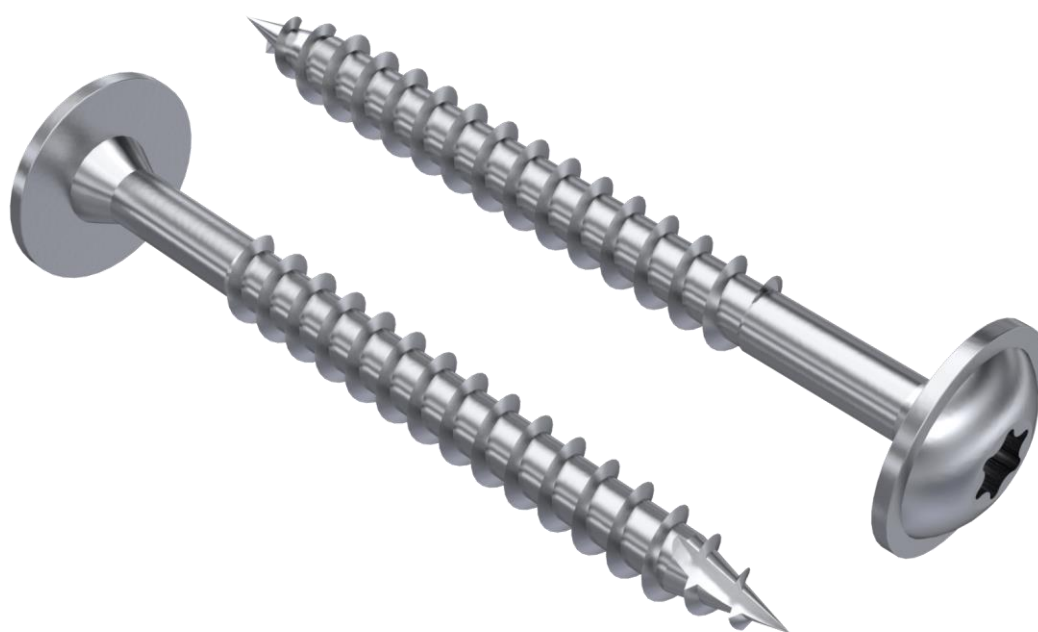

DATASHEET
ART. 9809

YOUR NEEDS
OUR MISSION

ART.9809

TECHNICAL SPECIFICATION

Ideal for outdoor screw connections such as solar panels, carports, balconies, footbridges, playground equipment, prefabricated houses. A minimum screw-in depth of 4 X the diameter must be guaranteed.

Ideally, a screw-in depth of 8 X the diameter should be achieved.

Material	Stainless Steel
Quality	A2
Surface	Lubrication

YOUR ADVANTAGES

HIGH SECURITY

- › Due to significantly higher head pull-through values compared to a countersunk head

COST EFFICIENT

- › Increased head pull-through values result in 50% fewer screws required

NO TEARING OUT THE WOOD

- › The cutting notch removes tension from the wood fibres and minimises the formation of cracks

LUBRICATION

- › Low screw-in resistance

APPLICATIONS

 PHOTOVOLTAICS

 CARPORTS

WE'D BE PLEASED TO ADVISE WITH YOUR APPLICATION.

DIMENSIONS (MM)

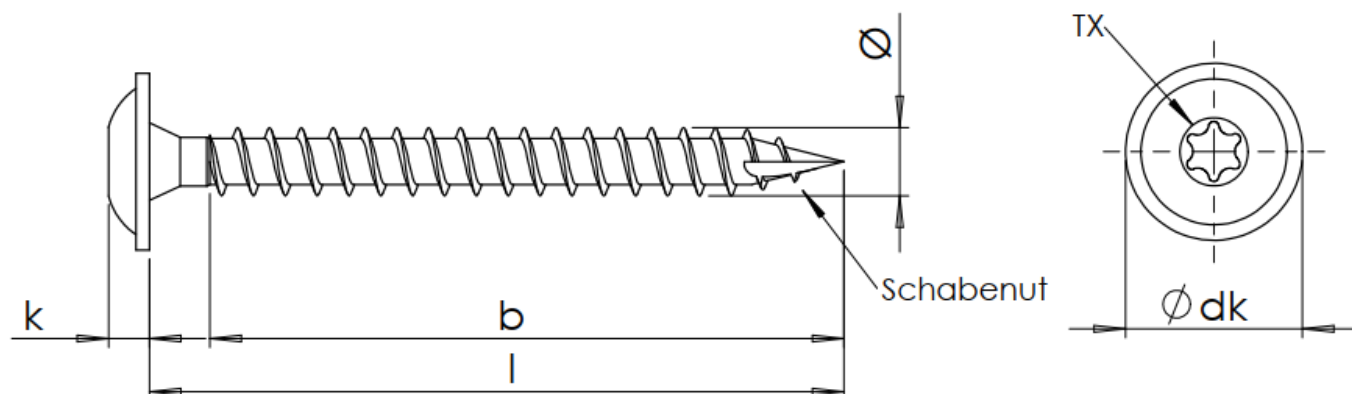

Thread Ø	6,0	8,0
d _k	15,0	20,0
k	3,8	4,6
Drive No.	TX25	TX40

Ø	6,0	8,0
Length l	b	
30	20	Full Thread
35	24	
40	24	
45	30	
50	30	
55	36	
60	36	50
65	42	50
70	48	50
80	54	72
90	70	80
100	70	80
110	70	80
120	70	80
130	70	80

WE'D BE PLEASED TO ADVISE WITH YOUR APLICATION.